

# SO4902M1X

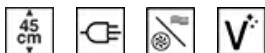

<b>Categorie</b>	45 cm
<b>Product familie</b>	Oven
<b>Stroomvoorziening</b>	Elektrisch
<b>Warmtebron</b>	Elektriciteit
<b>Bereidingswijze</b>	Combi-microgolf
<b>Galileo technologie</b>	Micro combi
<b>Reinigingssysteem</b>	Vapor Clean reiniging
<b>EAN-code</b>	8017709325718



## Design

<b>Design</b>	Victoria	<b>Type zeefdruk</b>	Symbolen
<b>Kleur</b>	Inox	<b>Deur</b>	Met paneel
<b>Design</b>	Bol	<b>Handvat</b>	Victoria
<b>Materiaal</b>	Gelakt materiaal	<b>Kleur handvat</b>	Inox look
<b>Type glas</b>	Clear1	<b>Logo</b>	Geassembleerd
<b>Kleur serigrafie</b>	Zwart		

## Bediening



<b>Display</b>	EvoScreen	<b>Aantal bedieningsknoppen</b>	2
<b>Display</b>	LCD	<b>Bedieningsknoppen</b>	Victoria
<b>Bediening</b>	Bedieningsknoppen	<b>Kleur bedieningsknoppen</b>	Inox look

## Programma's / Functies

<b>Aantal kookfuncties</b>	10
<b>Automatische programma's</b>	20

## Traditionele bereidingsfuncties



Statisch



Statisch + ventilator



Circulatie (ventilator + circulaire)



Turbo: ventilator + circulaire +

statisch



ECO



Grote grill



Onderwarmte



Pizza

## Bereidingsfuncties met microgolven



Microgolfoven



Microgolf + boven- en onderwarmte

+ ventilator



Microgolf + circulaire + ventilator



Microgolf + grill

## Overige functies



Ontdooien op tijd



Rijzen



Stone cooking



BBQ



Air-Fry



Sabbath

## Reinigingsfuncties



Vapor Clean reiniging

## Opties



### Tijdsinstelling

Automatische in- en uitschakeling

Timer

Ja

Timer

1

Kinderbeveiliging

Ja

### Andere opties

Warmhoudfunctie, Eco light, Geluiden, Helderheid

Showroom demo optie

Ja

Snel voorverwarmen

Ja

## Technische specificaties



Minimum temperatuur

30 °C

Maximum temperatuur

250 °C

Aantal kookniveaus

2

Deur

Temperatuur gecontroleerde deur

Type rekken	Metalen zijsteunen	Totaal aantal ruiten	3
Kantelbare grill	Ja	Automatische uitschakeling microgolf bij openen deur	Ja
Aantal lampen	2	Soft Close scharnieren	Ja
Type lamp	Halogeen	Soft open & close scharnieren	Yes
Vermogen lamp	40 W	Veiligheidsthermostaat	Ja
Verlichting bij opening deur	Ja	Chimney	Fixed
Onderwarmte - vermogen	1000 W	Koelsysteem	Mantelkoeling
Grill - vermogen	2000 W	Koelleiding	Enkel
Circulatie - vermogen	1400 W	Afmetingen bruikbare interne ovenruimte (hxbxd)	211x462x401 mm
Warmte onderbroken bij openen deur	Ja	Temperatuurcontrole	Elektronisch
Opening deur	Standaard opening	Materiaal ovenruimte	Ever Clean emaille
		Veiligheidsscherm microgolfdeur	Ja

## Prestaties / energielabel



Netto volume	40 l	Effectief vermogen microgolf	800 W
Aantal ovens	1		

## Meegeleverde accessoires

Ovenrooster met stop	1	Glazen ovenplaat	1
Inzetrooster	1		

## Elektrische aansluiting

Spanning	220-240 V	Frequentie	50 Hz
Nominale aansluitwaarde	3100 W	Lengte voedingskabel	115 cm

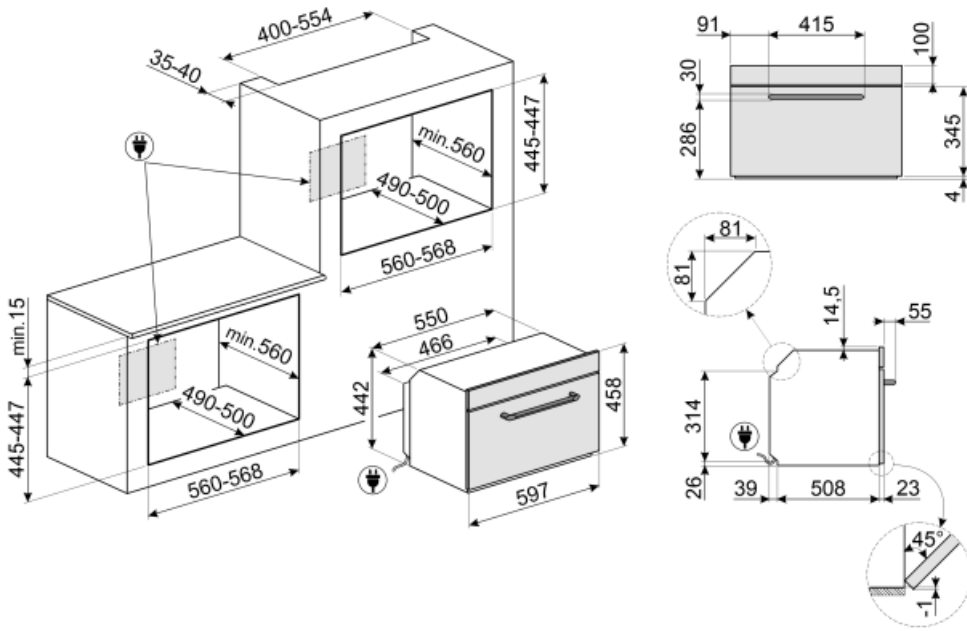















## Not included accessories



















---

AIRFRY



## Symbols glossary (TT)

 <p>Sommige modellen zijn voorzien van een functie om het programma/de cyclus te blokkeren zodat het niet per ongeluk kan aangepast worden.</p>	 <p>Combination microwave: This oven allows to combine two different ways of cooking (Traditional with microwaves). Combined ovens increase cooking opportunities, while providing maximum flexibility of household appliances.</p>
 <p>Air cooling system: to ensure a safe surface temperatures.</p>	 <p>Defrost by time: Manual defrost function. At the end of the set duration, the function stops.</p>
 <p>Triple glazed doors: Number of glazed doors.</p>	 <p>Automatic lighting deactivation: For greater energy savings, the lighting turns off automatically after one minute from the start of cooking. The option can be disabled via the settings menu. In this case the light will remain on for the entire duration of cooking.</p>
 <p>Elektrische aansluiting</p>	 <p>Ever Clean Enamel: Ever Clean enamel is applied electrostatically, corner to corner and edge to edge to prevent cracking or cracks over time. It is a particular pyrolytic enamel, resistant to acids which, in addition to being pleasantly bright, promotes greater cleaning of the oven walls, thanks to its lower porosity. It is baked at over 850 ° C and slowly polymerized at a scientifically determined rate to ensure uniform depth and strength. Ever Clean enamel creates an impeccable finish both on the inside of the oven and on the trays, making the surfaces of the oven incredibly easy to maintain over time as it reduces the adhesion of fat during cooking.</p>
 <p>Ventilator met bovenste en onderste elementen: De elementen in combinatie met de ventilator zijn bedoeld om een meer gelijkmatige warmte te bieden, een methode die vergelijkbaar is met conventioneel koken, dus voorverwarmen is vereist. Het meest geschikt voor items die langzaam koken vereisen.</p>	 <p>Alleen boven- en onder element: een traditionele kookmethode die het meest geschikt is voor losse items in het midden van de oven. De bovenkant van de oven zal altijd het heetst zijn. Ideaal voor gebraden vlees, fruitcake, brood etc.</p>
 <p>Base: the heat comes only from the bottom of the cavity. The fan is not active. Ideal for sweet and savory pies, cobbles and pizzas. Designed to complete cooking and make food more crunchy. This symbol in gas ovens indicates the gas burner.</p>	 <p>Circulaire: De combinatie van de ventilator en het ronde element eromheen zorgt voor een hete lucht kookmethode. Dit biedt vele voordelen, waaronder geen voorverwarmen als de kooktijd meer dan 20 minuten bedraagt, geen smaakoverdracht bij het gelijktijdig bereiden van verschillende soorten voedsel, minder energie en kortere kooktijden. Geschikt voor alle soorten voedsel.</p>
 <p>De combinatie van de grill, de ventilator en onderwarmte is interessant voor het bereiden van kleine hoeveelheden.</p>	 <p>Grill: Very intense heat coming only from above from a double heating element. The fan is not active. Provides excellent grilling and gratinating results. Used at the end of cooking, it gives a uniform browning to dishes.</p>

- |   |  |
|---|--|
|  <p><b>Microwave:</b> Penetrating straight into the food, microwaves cook very quickly and with considerable energy savings. Suitable for cooking without fat, they are also able to thaw and heat food without altering its original appearance and aroma. The microwave function can also be combined with conventional functions with all the resulting advantages. Ideal for all types of food.</p> |  <p><b>Cooking with the simultaneous use of the heating element in combination with fan and microwave supply.</b></p>   |
|  <p><b>Microwave + grill element:</b> The use of the grill results in a perfect browning of the surface of the food. The action of microwaves allows instead of cooking in a short time the internal part of the food.</p>  |  <p><b>Fan combined with traditional cooking, where heat is generated from above and below, provides uniform heat. Adding the microwave function allows the same cooking results in less time.</b></p>  |
|  <p><b>Pizza function:</b> Specific function for cooking pizza in a pan. It allows to obtain a pizza that is soft inside and crispy outside with the topping perfectly cooked, not dry and not burnt.</p>   |  <p><b>Circulaire met bovenste en onderste elementen:</b> door het gebruik van de ventilator met beide elementen kan voedsel snel en effectief worden gekookt, ideaal voor grote stukken vlees die grondig moeten worden gekookt. Het biedt een vergelijkbaar resultaat als rotisserie, waarbij de warmte rond het voedsel wordt verplaatst in plaats van het voedsel zelf te verplaatsen, waardoor elke maat of vorm kan worden gekookt.</p> |
|  <p><b>Compacte toestellen met een hoogte van 45 cm - perfecte oplossing om te voldoen aan de functionele eisen van keukensets met een kleine hoogte. Verkrijgbaar in verschillende soorten en in verschillende stijlen.</b></p>  |  <p><b>Met deze functie kan u bereidingen warmhouden zodat het eten niet meteen afkoelt</b></p>   |
|  <p><b>Side lights:</b> Two opposing side lights increase visibility inside the oven.</p>   |  <p><b>Air at 40°C provides the perfect environment for proving yeast type dough mixes. Simply select the function and place dough in the cavity for allotted</b></p>   |
|  <p><b>Rapid preheating:</b> cooking is preceded by the preheating phase which allows the cooking compartment to reach the set temperature. This option reduces the time by up to 50%.</p>  |  <p><b>SABBATH:</b> function that allows to cook food respecting Judaism's day of rest provisions.</p>  |
|  <p><b>The oven cavity has 2 different cooking levels.</b></p>  |  <p><b>Alle modellen zijn voorzien van een soft close deursysteem waarbij de deur zacht en stil sluit.</b></p>  |
|  <p><b>Electronic control:</b> Allows you to maintain temperature inside the oven with the precision 2-3 ° C. This enables to cook meals that are very sensitive to temperature changes, such as cakes, souffles, puddings.</p>   |  <p><b>Tilting grill:</b> the tilting grill can be easily unhooked to move the heating element and clean the roof of the appliance in one simple step.</p>  |
|  <p><b>Vapor Clean:</b> a simple cleaning function using steam to loosen deposits in the oven cavity.</p>   |  <p><b>The capacity indicates the amount of usable space in the oven cavity in litres.</b></p>  |



EVOscreen display + bedieningsknoppen



Speciale kookfunctie voor de dubbelzijdige plaat-BBQ. Geschikt voor het nabootsen van sappige en knapperige gerechten in de oven met de typische smaak van gegrild koken. De geribbelde kant is bijzonder geschikt voor vleeswaren en kazen; de gladde kant voor vis, zeevruchten en groenten.



Speciale kookfunctie voor het Airfryerrek AIRFRY. Ideaal voor het nabootsen van traditioneel frituren in de oven, maar met minder calorieën en minder vet. Hiermee kook je snel en eenvoudig gerechten zoals frites, gebakken groenten en vis, waardoor ze perfect bruin en krokant worden.



Speciale kookfunctie voor de pizzasteen STONE. Ideaal voor het bakken van pizza's met hetzelfde resultaat als een typische houtgestookte oven. Kan ook worden gebruikt voor het bakken van brood, focaccia's en andere recepten zoals taarten, vlaaien of koekjes